

20" C515 FLG X FLG

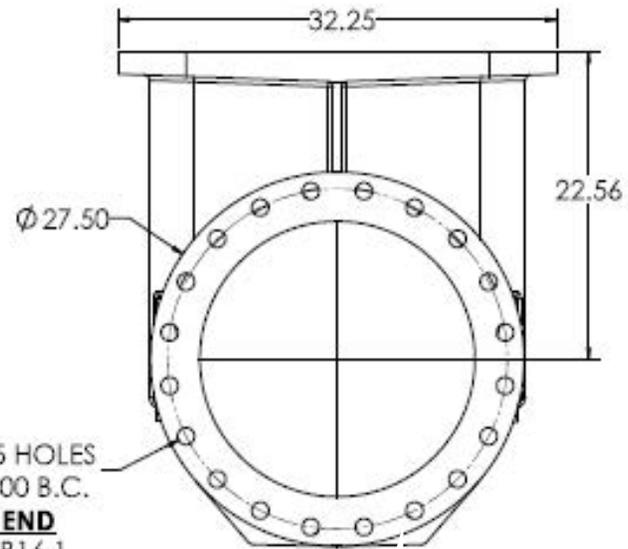
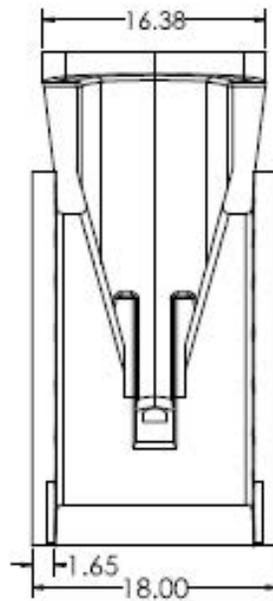

20 x \varnothing 1.25 HOLES
ON \varnothing 25.00 B.C.
FLG END
ANSI B16.1
CLASS 125

OTHER END CONNECTIONS ARE AVAILABLE UPON REQUEST.

OS&Y VALVE CO. 12000 W. 120th St., Omaha, NE 68144 (402) 426-1000		ALL DIMENSIONS UNLESS OTHERWISE SPECIFIED ARE IN INCHES AND DECIMALS THEREOF. DIMENSIONS IN PARENTHESES ARE IN MILLIMETERS.		DRAWN BY: DW	CHECKED BY: T24K20	DATE: 1/6	PROJECT: 20" C515 OS&Y RESILIENT WEDGE GATE VALVE	SHEET NO. 7	TOTAL SHEETS 7	SCALE: 1:6	MATERIAL: LBS.	WEIGHT: 1249.00	PART NO. 20C515	REV. D
--	--	--	--	-----------------	-----------------------	--------------	--	----------------	-------------------	---------------	-------------------	--------------------	--------------------	-----------

SPUR GEAR WITH OP NUT

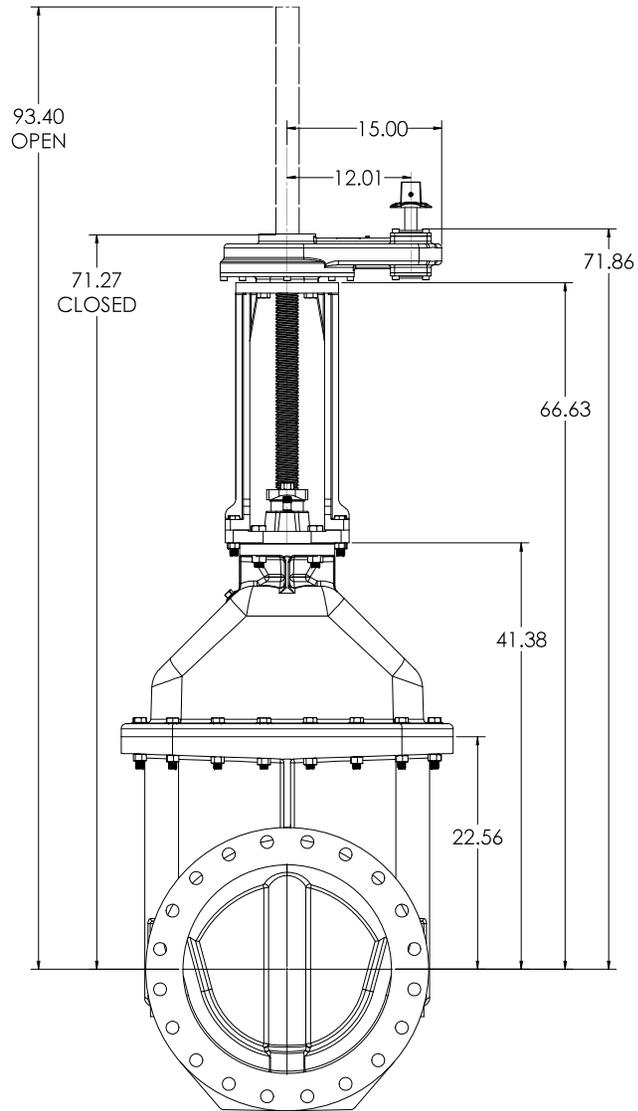

BEVEL GEAR WITH OP NUT

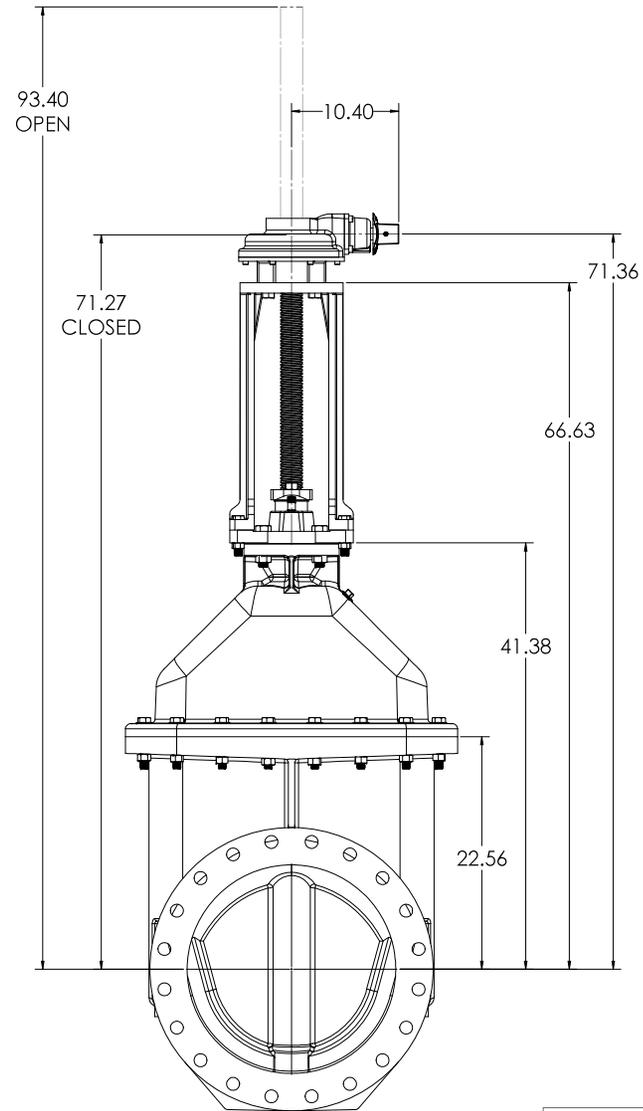

DWG NO: 134620 DATE: 11/11/16 DRAWN: DWI CHECKED: TSG APPROVED: TSG		PROJECT NO: 134620 PROJECT NAME: 20" CS15 CS&Y RESILIENT WEDGE GATE VALVE SHEET NO: 7 TOTAL SHEETS: 7		SCALE: T:6 MATERIAL: LBS MANUFACTURER: SolerWorks 2016 SPZ		2 D
---	--	--	--	--	--	--------

SPUR GEAR WITH HANDWHEEL

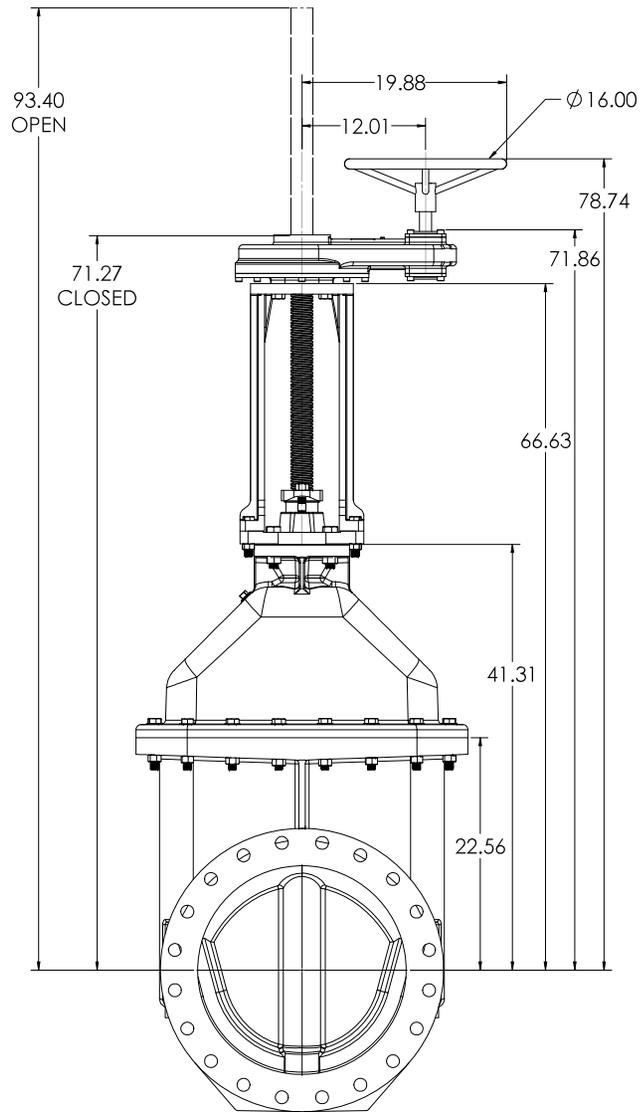

BEVEL GEAR WITH HANDWHEEL

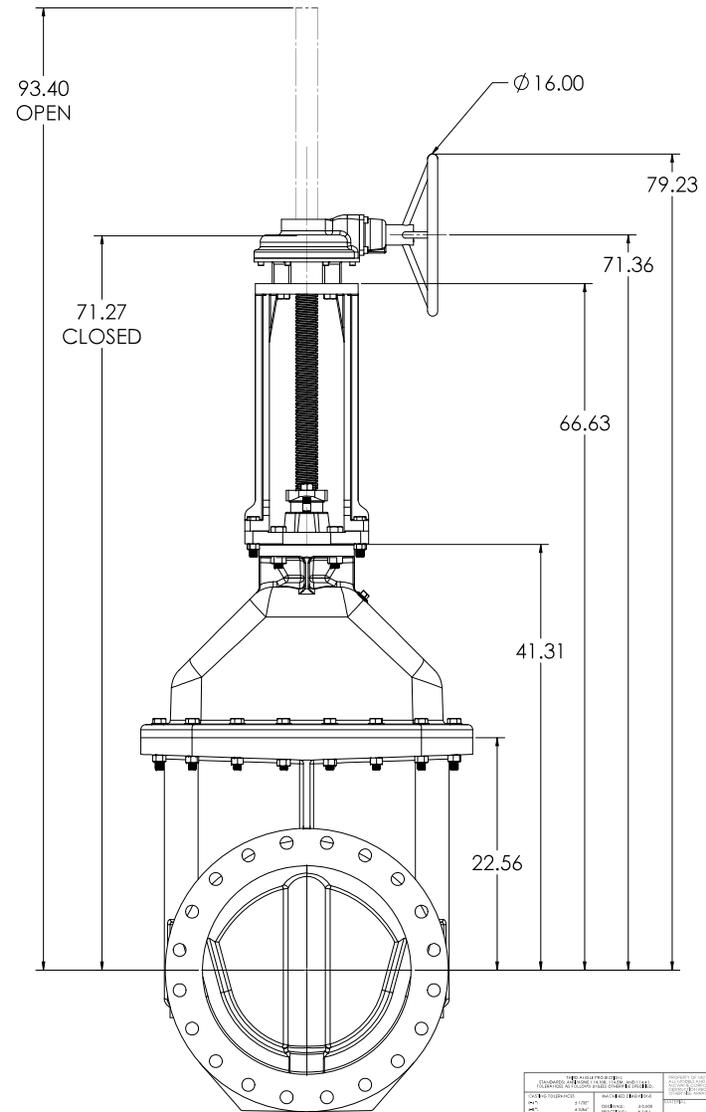

DWG NO: 124420 DATE: 1/20/16 DESIGNED BY: DWI CHECKED BY: DWI APPROVED BY: DWI		PROJECT NO: 124420 PROJECT NAME: 20" CS15 CS&Y RESILIENT WEDGE GATE VALVE SCALE: T:6 SHEET NO: 3 TOTAL SHEETS: 7		
--	--	--	--	--

BARE STEM ASSEMBLY

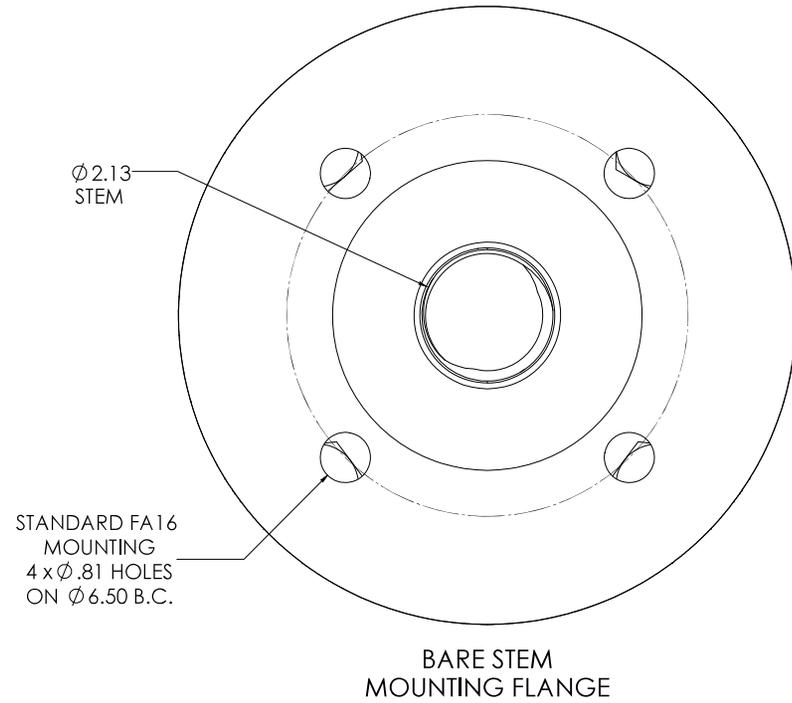
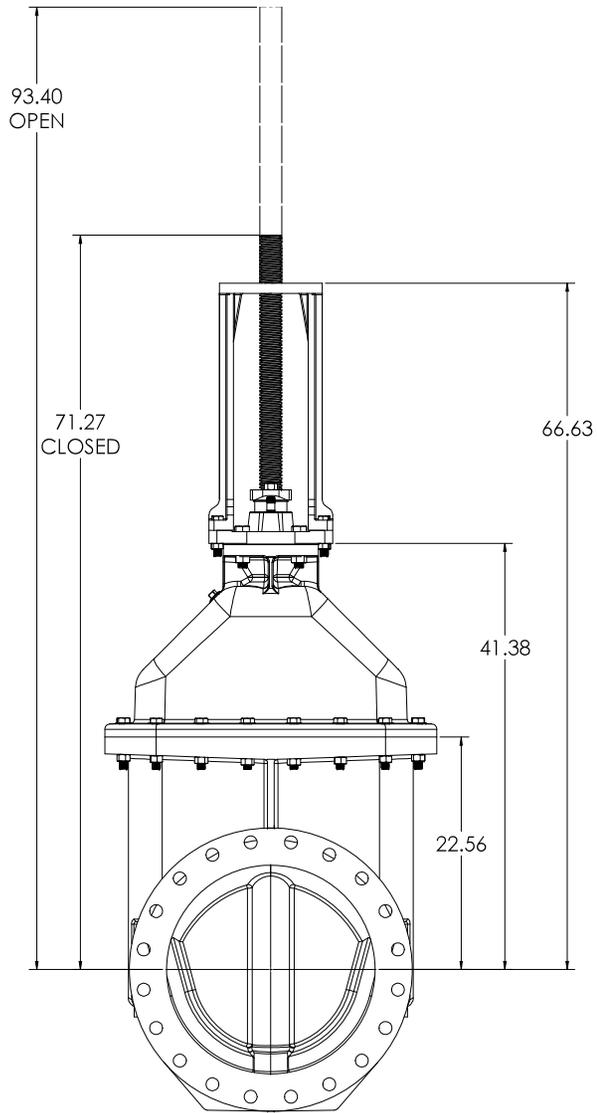

COMPANY: SOLOWORKS ADDRESS: 10000 W. 16th Ave., Suite 100, Golden, CO 80401 PHONE: (303) 440-9400 FAX: (303) 440-9401 WWW: www.soloworks.com		PROJECT: 20" CS15 CS&Y RESILIENT WEDGE GATE VALVE DRAWING NO: 1340420 DATE: 1/2/20		SHEET NO: 4 TOTAL SHEETS: 7	
DESIGNED BY: AW CHECKED BY: AW DATE: 1/2/20	DRAWN BY: AW CHECKED BY: AW DATE: 1/2/20	SCALE: LBS. UNIT: T:6	PROJECT NO: 1340420 SHEET NO: 4 TOTAL SHEETS: 7	PROJECT NAME: 20" CS15 CS&Y RESILIENT WEDGE GATE VALVE	SHEET TITLE: 4 TOTAL SHEETS: 7
DWG: 1340420			SOLOWORKS 2018 SP2		

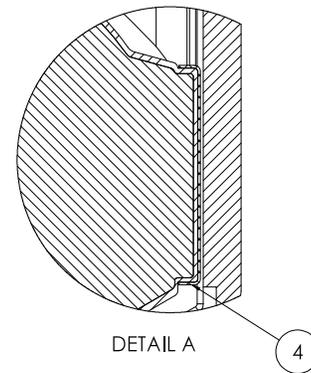
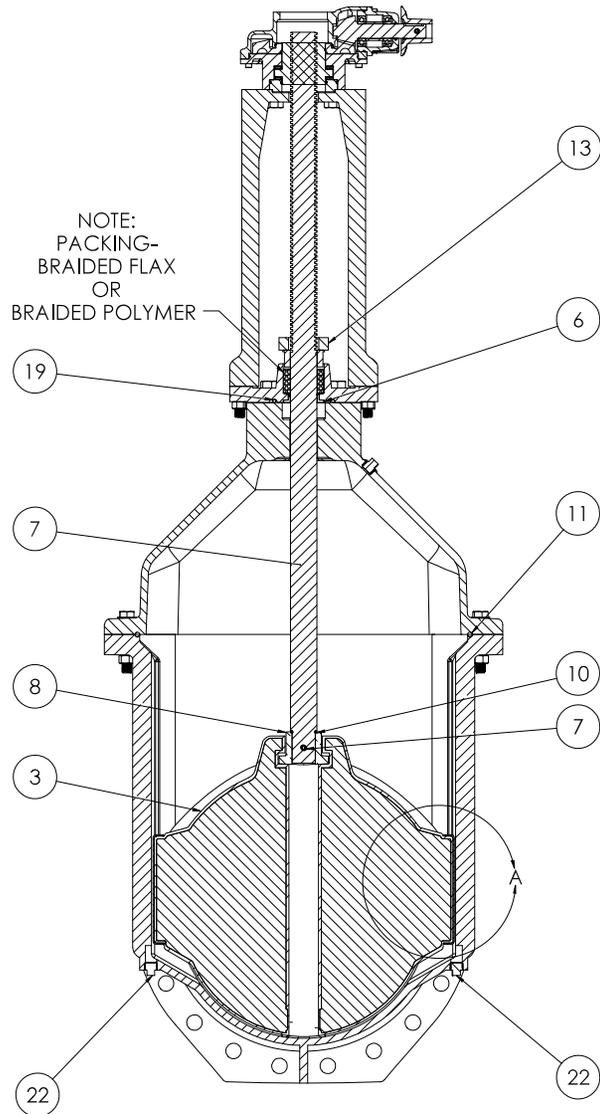
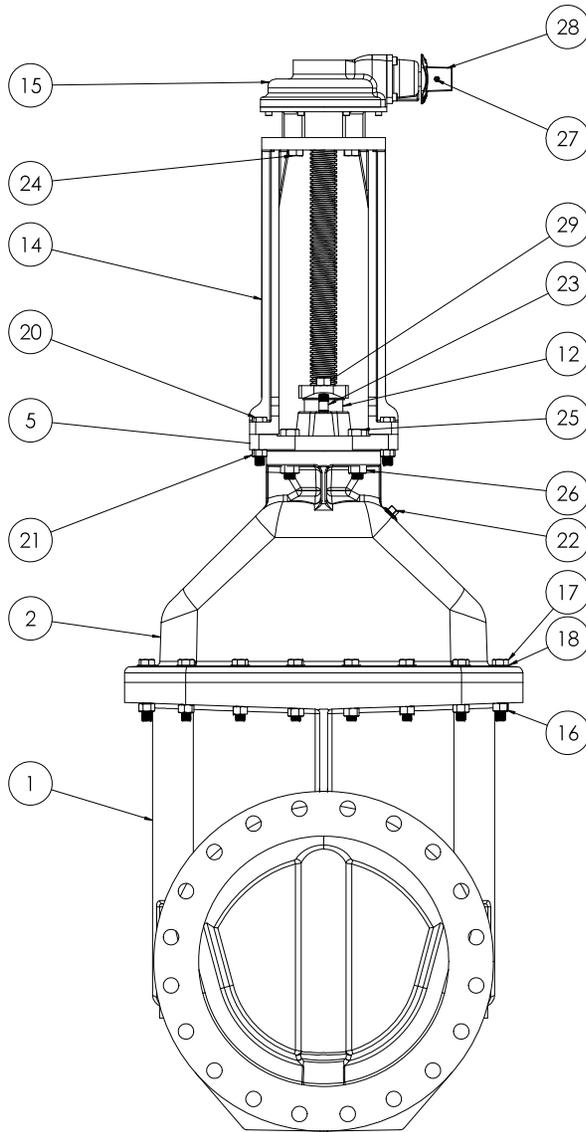

DWG NO: 134620 DATE: 01/15/16 DESIGNED BY: [REDACTED] CHECKED BY: [REDACTED]		PROJECT NO: [REDACTED] PROJECT NAME: [REDACTED]		SHEET NO: 5 TOTAL SHEETS: 7	
TITLE: 20" CS15 CS&Y RESILIENT WEDGE GATE VALVE		SCALE: 1:5		DRAWN BY: DWI DATE: 1/15/16	

ITEM NO.	COMPONENT	QTY.	SIZE	STANDARD MATERIAL	MATERIAL OPTIONS
1	BODY	1	-	DUCTILE IRON	-
2	COVER	1	-	DUCTILE IRON	-
3	WEDGE	1	-	DUCTILE IRON/EPDM	-
4	WEDGE CAP	2	-	DELRIN	-
5	STUFFING BOX	1	-	DUCTILE IRON	-
6	BUSHING	1	-	C87850	-
7	STEM	1			
8	STEM NUT	1	2 1/8"	C65500	304 SS, 316 SS
9	COILED SPRING PIN	1	1/2" X 3 1/4"	303 SS	-
10	O-RING	1	#327	EPDM	BUNA-N
11	O-RING	1	#469	EPDM	BUNA-N
12	GLAND	1	-	C87850	-
13	FOLLOWER PLATE	1	-	GREY IRON	-
14	YOKE	1	-	CAST IRON	-
15	BEVEL GEAR	1	1B7	-	-
29	HEX NUT	16	3/4" - 10	18-8 SS	316 SS
17	HEX HEAD CAPSCREW	16	3/4" X 4 1/2"	18-8 SS	316 SS
18	FLAT WASHER	16	3/4"	18-8 SS	316 SS
19	O-RING	1	#425	EPDM	BUNA-N
20	HEX HEAD CAPSCREW	8	5/8" X 3 1/2"	18-8 SS	316 SS
21	HEX NUT	8	5/8" 11	18-8 SS	316 SS
22	PIPE PLUG	3	1" - NPT	304 SS	316 SS
23	STUD	2	3/4" X 3 3/4"	YELLOW ZINC	-
24	HEX HEAD CAPSCREW	4	3/4" X 3 1/2"	18-8 SS	316 SS
25	HEX HEAD CAP SCREW	4	7/8" X 3 1/2"	18-8 SS	316 SS
26	HEX NUT	4	7/8" - 9	18-8 SS	316 SS
27	COILED SPRING PIN	1	10mm X 45mm	302 SS OR 304 SS	-
28	OPERATING NUT	1	-	CAST IRON	304 SS, C86700 ** Ø 16" HANDWHEEL**
29	HEX NUT	2	3/4" - 10	BRASS	-

- VALVES CONFORM WITH FOLLOWING STANDARDS
 - AWWA C515
 - NSF 61
- LOW ZINC BRASS STEM AND STEM NUT AVAILABLE
- 100% DOMESTIC FASTENER AND O-RING OPTIONS AVAILABLE
- OPEN LEFT (COUNTERCLOCKWISE) AND OPEN RIGHT (CLOCKWISE) OPTIONS AVAILABLE
- TURNS TO OPEN FROM FULLY CLOSED: 228
 - +/- 5% WITH STANDARD 3:1 BEVEL OR SPUR GEAR
- AWWA MAXIMUM ALLOWABLE CLOSING TORQUE 250 FT-LBS WITH STANDARD GEARING
- OPTIONAL HANDWHEEL CAN BE SUBSTITUTED FOR STANDARD 2" SQUARE OP NUTS
 - **NOTE: STANDARD HANDWHEEL SIZE CALLED OUT IN PARTS LIST**

<small> COMPANY: WATERWORKS ADDRESS: 11000 W. 104th St., Overland Park, KS 66204 PHONE: (913) 241-1000 FAX: (913) 241-1001 WWW: www.waterworksinc.com </small>		<small> PROJECT: 20" CS15 CS&Y RESILIENT WEDGE GATE VALVE LBS: 6 T:5 </small>		
<small> DATE: 11/11/2016 TIME: 10:00 AM USER: DWI </small>	<small> PROJECT: 124620 </small>	<small> SCALE: 1:5 </small>	<small> SHEET: 6 TOTAL: 7 </small>	<small> DWG: 124620 DATE: 11/11/2016 </small>